



MODEL: MEMPHIS

**CD/USB/SD PLAYER WITH TURNTABLE.
ENCODING TO USB AND SD CARD.
FM STEREO RADIO**

OPERATING INSTRUCTIONS

**PLEASE READ THIS USER MANUAL COMPLETELY BEFORE
OPERATING THIS UNIT AND RETAIN THIS BOOKLET FOR FUTURE
REFERENCE.**

SAFETY INSTRUCTIONS

WARNING: TO PREVENT FIRE OR SHOCK HAZARD, DO NOT EXPOSE THIS APPLIANCE TO RAIN OR MOISTURE.

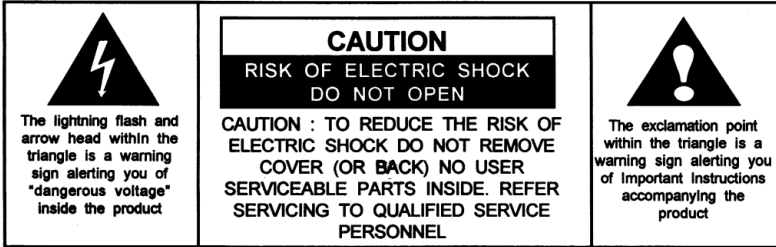

IMPORTANT SAFETY INSTRUCTIONS

- **Read instructions** - All the safety and operating instructions should be read before the appliance is operated
- **Retain instructions** - The safety and operating instructions should be retained for future reference.
- **Heed Warnings** - All warnings on the appliance and in the operating instructions should be adhered to.
- **Follow instructions** - All operation and user instructions should be Followed.
- **Water and Moisture** - The appliance should not be used near water; for example, near a bathtub, wash-bowl, kitchen sink, laundry tub, in a wet basement, or near a swimming pool etc.
- **Heat** - The appliance should be situated away from heat sources such as radiators, heat registers, stoves or other appliances (including amplifiers) that produce heat.
- **Power Sources** - The appliance should be connected to a power supply only of the type described in the operating instructions or as marked on the appliance
- **Cleaning** - The appliance should be cleaned only as recommended by the manufacturer.
- **Object and Liquid Entry** - Care should be taken so that objects do not fall and liquids are not spilled into the enclosure through openings.
- **Damage Requiring Service** - The appliance should be serviced by qualified service personnel when:
 - The power supply cord or the plug has been damaged
 - Objects have fallen, or liquid has been spilled into the appliance
 - The appliance has been exposed to rain
 - The appliance does not appear to operate normally or exhibits a marked change in performance
 - The appliance has been dropped, or the enclosure damaged.
- **Servicing** - The user should not attempt to service the appliance beyond that described in the operating instructions. All other servicing should be referred to qualified service personnel.

LOCATION OF CONTROLS

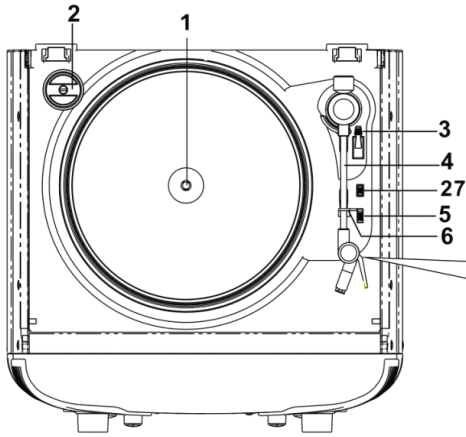

Before use, detach the stylus guard (white plastic cover) by pulling it straight off the front of the cartridge in the direction of the arrow.

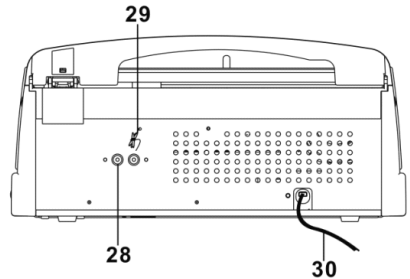
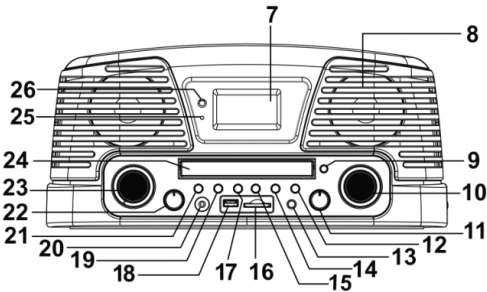

- | | |
|---|---|
| <ul style="list-style-type: none"> 1. Turntable 2. 45 RPM Adaptor 3. Cue-lever (use this lever to lift the tone arm.) 4. Tone Arm 5. Speed Selector 6. Tone arm Holder 7. Display 8. Speakers 9. Open / Close Button 10. Tuning Control 11. FM / FM STEREO BUTTON 12. Mode Button (Program, Repeat 1, Repeat Album, Repeat All ,Random) 13. BBS Button 14. Skip + Button 15. Skip - Button 16. SD/MMC Card Slot | <ul style="list-style-type: none"> 17. Stop/ CD/USB/SD Button 18. USB Port 19. Play / Pause Button 20. AUDIO-IN-Jack 21. Record-Button 22. Function Selector 23. Volume Control 24. CD Door 25. Power Indicator 26. IR Sensor 27. Auto Stop (ON/OFF) Selector 28. Aux Line-Out output Socket 29. FM Antenna 30. AC Power Cord |
|---|---|

Remark : Saving energy when the unit has no sound output on turntable player mode, CD mode and USB/SD mode in about 15 minutes, it will be switched to stand-by automatically. It can be switched ON the unit by switching the function selector again.

FM RADIO

1. Set the Function Selector (22) to the Radio position.
2. Select the desired frequency band with FM / FM STEREO Selector (11).
3. Tune to the desired radio station by turning the Tuning control (10).
4. Adjust the volume (23) control to desired level.
5. To turn off the radio, set the Function Selector (22) to the Power OFF position.

TURNTABLE OPERATION

Preparation

- Open the record player cover, release the tone arm clamp and remove the stylus protector.

Listening to Records

1. Set the Function Selector (22) to the PHONO position.
2. Place a record on the turntable, over the central spindle. (Place the EP adapter over the central spindle when playing 17cm EP records)
3. Set the Speed Selector (5) to 33 or 45 or 78 rpm according to the record.
4. Release the tone arm clamp, and remove the protective cap from the stylus.
5. Lift the Tone arm with the Tone arm Lift Lever.
6. Move the tone arm to the beginning of the record, or to the start of a particular track.
7. Gently lower the tone arm onto the record with the Tone arm Lift lever to start playing.
8. When the record is finished the tone arm will automatically stop. Lift the tone arm from the record and return it to the rest.
9. To stop manually, lift the tone arm from the record and return it to the rest position.

Auto stop ON / OFF selector

- Auto stop will function when playing records (singles) at EP 33 RPM. To set the auto stop selector, switch Auto Stop switch (27) to **“ON”** for turntable auto stop function.
- **Note:** When playing **EP 45 or 78 RPM** – Switch Auto stop (27) to the “Off” position. This enables the whole album to play.

Replace the protective cap on the stylus when not in use.

COMPACT DISC/MP3 OPERATION

LOADING AND UNLOADING COMPACT DISCS

1. Select CD/MP3 with the Function selector (22) on the unit to choose the CD/MP3 mode.
2. Open the disc compartment by pressing the CD Open Button (9).
3. When the disc compartment has opened, remove a disc from its case and place it
4. carefully in the compartment with the label side facing up. Locate smaller, discs, in
5. the centre depression of the compartment.
6. Close the disc compartment.
7. When the compartment is fully closed, the disc will start turning automatically. The total
8. number of tracks of the CD will appear on the LCD display.

LISTENING TO COMPACT DISC AND MP3 DISC (CD)

1. Select CD with the Function selector (22) on the unit to choose the CD mode.
2. Press the PLAY/PAUSE button on the unit once to start playing the CD From the first track, and “play” indicator will appear on the display.
3. Press the PLAY /PAUSE button again to playing the CD “pause” indicator will appear on the display(the track number is flash).
4. To stop playback, press the “Stop/CD/USB/SD” button.

TRACK SKIP CD-

1. Press the SKIP / SEARCH (REW. or F.F.) button on the unit (14,15)

TRACK SKIP MP3-

1. FOLDER UP /DOWN by **REMOTE** (9,10), the Album no. will change.
2. Press SKIP +/SKIP - (REW. or F.F.) buttons (14,15)the Track no. will change.

PROGRAMMED DISC PLAY (CD)

It is not possible to enter programs during disc play. Press the Stop button (17) first, then follow the instructions below.

1. Press the PROGRAM button(MODE)Button(12) on the unit . The following information will be displayed on the CD Display.
2. Press the Forward and Reverse Skip Track buttons (14,15) on the unit to select the track to be stored in location i.e. track 03.
3. Press the PROGRAM (mode) button. The first program selection is now stored in the program memory.

Listening to Programmed Tracks

Press the Play Pause button. Disc play will start at the beginning of the first programmed track. To Clear The Program Memory If the disc is playing, press the Stop button to stop the disc.

PLAY AUDIO VIA MP3 PLAYER OR SMARTPHONE (not supplied)

1. Using supplied 3.5mm jack lead, connect one end to the headphone socket on mp3 player and the other side to the Audio-In jack (20) on the Memphis Vinyl Player.
2. Change function selector (22) to "Audio line in"
3. Operate your mp3 player as directed by your manufacturer.

USB- CARD OPERATION

1. Insert the USB or SD card.
2. Switch FUNCTION button to the position of CD/USB/SD as below diagram:

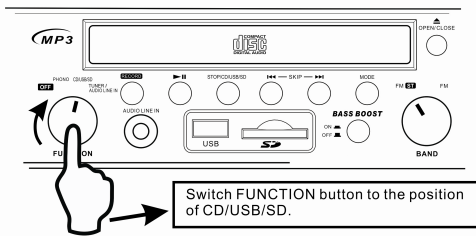

3. Press this button on the unit for 2 seconds to select the CARD-USB mode as below diagram:

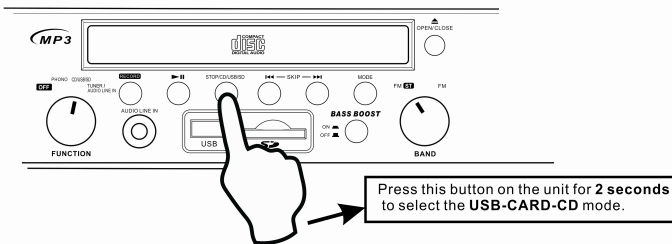

4. The unit will automatically read the total folders and the number of the total tracks.

NOTE: Only Mp3 file format is supported.

***Not all brands of USB flash disc are supported.**

PLAYING

1. Playback starts with the first track, the display shows the current track number.
2. To interrupt playback, press PLAY/PAUSE button. The time elapsed indicator will flash.
3. To resume playback, press the PLAY/PAUSE again.
4. To stop playback, press the STOP button.

ENCODING AND STORING FROM A NORMAL CD

You can encode you favourite CD songs into mp3 format and store them into your memory device through the USB port or SD/MMC card slot.

1. Set the Function Selector (22) on the unit to choose the CD mode
2. Press the SKIP +/- button(14,15) to select the track ,then press the PLAY/PAUSE button (19)to be encoded.
3. Press the RECORD button(21) to start sync encoding and the display will show "USB or CARD" flashing ,
4. Press the SKIP +/- button(14,15) to select recording into USB or Card drive, press the RECORD button to confirm.
5. Press the Record button(21) or STOP/CD/USB/SD button(16) to stop encoding.
6. Remarks: Recording CD must be synchronized and press the STOP/CD/USB/SD button to confirm.

NOTE: Some CD's are copyrighted which means that you may not be able to encode from them. Always make sure you are allowed to copy from the format you are working with and that you are not infringing any copyright laws

ENCODING AND STORING FROM PHONO.

You can encode your favourite EP songs into mp3 format and store them into your memory device through the USB port or SD/MMC card slot.

1. Set the Function Selector (22) to the PHONO position
2. Select the track no. to be encoded.
3. Press the Record button to start sync encoding and the display will show "USB or CARD" flashing.
4. Press the SKIP +/- button(14,15) to select recording into USB or Card drive.
5. Press the Record button(21) or STOP/CD/USB/SD button(16) to stop encoding

COPYING FROM MP3 DISC

You can copy the files from an mp3 disc and store them into your memory device through the USB port or SD/MMC card slot.

1. Insert the mp3 disc.
2. Press the SKIP +/- button (14,15) to select the track ,then press the PLAY/PAUSE button (19) that you want to copy.
3. Press the encoding button to start copying the files and the display will show "REC" "USB/CARD" flash.
4. Press the SKIP +/- button (14,15) to select into USB or Card drive.
5. Press the Record button (21) or STOP/CD/USB/SD button(17) to stop encoding.

COPY FROM USB TO SD OR FROM SD TO USB

1. You can copy the files from MP3 or USB drive and store them into your memory device through the USB port or SD/MMC card slot.
2. Insert the MP3 player or USB drive into USB slot and SD CARD into SD card slot. Switch the function button to USB.
 - Press button "STOP / USB / SD" for more than 3 second to change USB/CARD mode, and press the RECORD button, the LCD will display "COPY USB > SD".
 - The display will be counted from 1 to 100% during recording.
 - Do not interrupt during copy recording process until completed, otherwise, recording function cannot be performed.
3. Insert the SD card and the MP3 player or USB drive into USB slot. Switch the function button to CD/MP3/USB/SD, then press button "STOP / USB / SD" for more than 3 second to change USB/CARD mode, and press the RECORD button, the LCD display "COPY SD > USB".

The display will be counted from 1 to 100%.
Do not interrupt during copy recording process until completed. Otherwise, recording function cannot be performed.

REMOTE CONTROL UNIT

Insert CR2025 battery before use.

1. PLAY/PAUSE BUTTON
2. RECORD BUTTON
3. STOP/CD/USB/SD BUTTON
4. SKIP- BUTTON
5. SKIP+ BUTTON
6. OPEN BUTTON
7. PROG BUTTON
8. MODE BUTTON
9. FOLDER UP
10. FOLDER DOWN
11. Remote Sensor

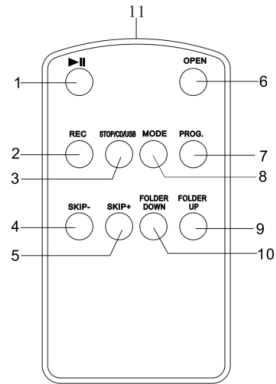

STYLUS REPLACEMENT

Loosen the red part of the stylus by screwdriver and take out as per diagram A and B

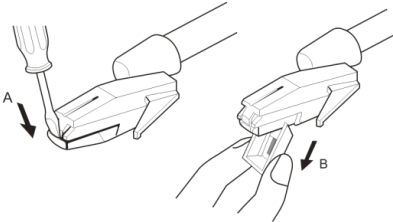

Replace the new stylus as per C and D diagram

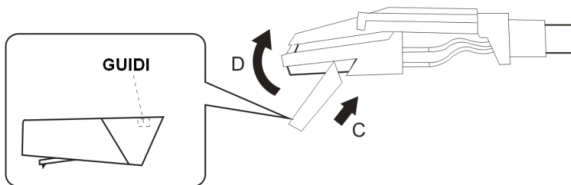

THE ABOVE DIAGRAM IS ONLY SHOWING HOW TO REPLACE A NEW NEEDLE/STYLUS.
(EXTRA 1 PIECE STYLUS/NEEDLE IS INCLUDED).

WARRANTY & SUPPORT

Your ProTelX product has been carefully manufactured and 100% tested using high quality assured components. It is guaranteed against faulty workmanship and materials for a period of 12 months from the date of purchase. In the unlikely event that failure should occur, the unit will be repaired or replaced free of charge when returned postage paid to the address below within the guarantee period.

The guarantee does not include damage or failure resulting from misuse or damage in transit. Your statutory rights under common law are in no way affected by this guarantee.

For service in or out of the guarantee period, please return the unit postage paid to the ProTelX address below.

When returning your unit please ensure that the package contains a covering letter stating where and when the unit was purchased and the nature of the faults plus your proof of purchase.

*Repair or replacement is at the discretion of the manufacturer.

ProTelX reserves the right to change product specification without prior notice.

ProTelX

Suite B
Floor 8 St James House
Pendleton Way
Salford
Manchester
M6 5FW

**You may wish to call our customer service department on
0845 521 4095**